



# Fluid control equipments

No. 77/500, T.N.C.C Building, Annasalai,  
Teynampet, Chennai - 600 006.

Telefax: +91-44-24481130  
E-mail : flu\_con@vsnl.com  
Website: www.flu-con.com

## POLYPROPYLENE “EXECUTOR”

## FILTER PRESS (Series-600)

We are leading manufacturers of pressure filtration equipments in Tamilnadu for over 35 years. The Executor series filter presses are ideal work horses providing filtration capacities in the range of 5 to 50 KLD of slurry per day. We have supplied more than 1000 presses to various clients all over India, and to countries like Bangladesh, Malaysia, Srilanka, Jordan etc., with various stages of automation. We custom build filter presses according to customer needs after conducting pilot studies.

### **FILTER PRESS : WHAT IS IT?**

Filter press is a device which is used for separating suspended solids from the liquids. In the plate&frame type the plates, the frames, and the plate accessories of the filter press are placed on two horizontal parallel bars and are pressed together in between two end plates (i.e. Fixed and moving ends) by a closing device. The material to be filtered is then pumped into the press which goes to all the frames where the filter media stops the suspended solids and allows only the clear liquid to go through the discharge ports leaving the solids in the frame.

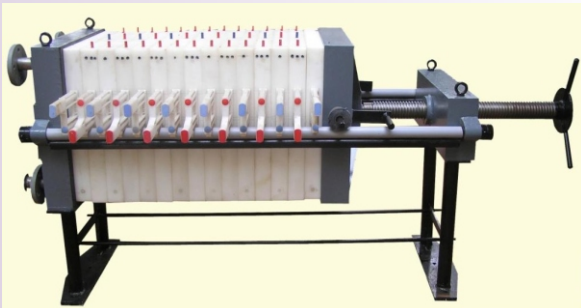

In the recessed type, the slurry is fed through the central inlet and the solids are retained in the recess between the plates, while the filtrate is collected through the corners.

## SOME OF OUR DISTINGUISHED CLIENTS

### **FOOD AND BEVERAGES**

INDO NISSION FOODS LTD  
MEGA TRENDS INC (TORINO)  
KALIMARK BEVERAGES LTD

### **EFFLUENT AND SEWAGE TREATMENT CONSULTANTS**

AQUA DESIGN INDIA LTD  
LIVING WATERFINE TECHNOLOGIES PVT LTD  
QUALITY WATER MANAGEMENT SYSTEMS PVT LTD

### **HERBAL AND BIOTECHNOLOGY**

KOTHARIPHYTO CHEMICALS INTERNATIONAL  
MALLADI DRUGS AND PHARMACEUTICALS  
THANGAM EXTRACTS

### **BATTERIES**

INDO NATIONAL GROUP (NIPPO BATTERIES)  
AMARA RAJA INDUSTRIES LTD (AMARON BATTERIES)  
TAFE POWER SOURCE DIVISION

### **TEXTILES AND LEATHERS**

BASIC CHEMICALS & INTERMEDIATES  
TEXTAN CHEMICALS PVT LTD  
RISHAB INTERMEDIATES

### **CHEMICAL INDUSTRIES**

CHEMPLAST SANNAR PVT LTD  
SOUTHERN CHEMICALS PVT LTD  
AAR VEE CHEM

### **RUBBER AND LATEX PROCESSING**

COMFOAMS LTD  
MARDEC LATEX PVT LTD  
R.K. LATEX PVT LTD

### **GOVT. INDUSTRIES AND LABS**

CENTRAL LEATHER RESEARCH INSTITUTES  
INDIAN INSTITUTE OF TECHNOLOGY, MADRAS  
MURHOPYE SCIENTIFIC

# SPECIFICATION

## FILTRATION AREA AND CAKE HOLDING VOLUME CHART FOR RECESSED & PLATE AND FRAME FILTER PRESSES

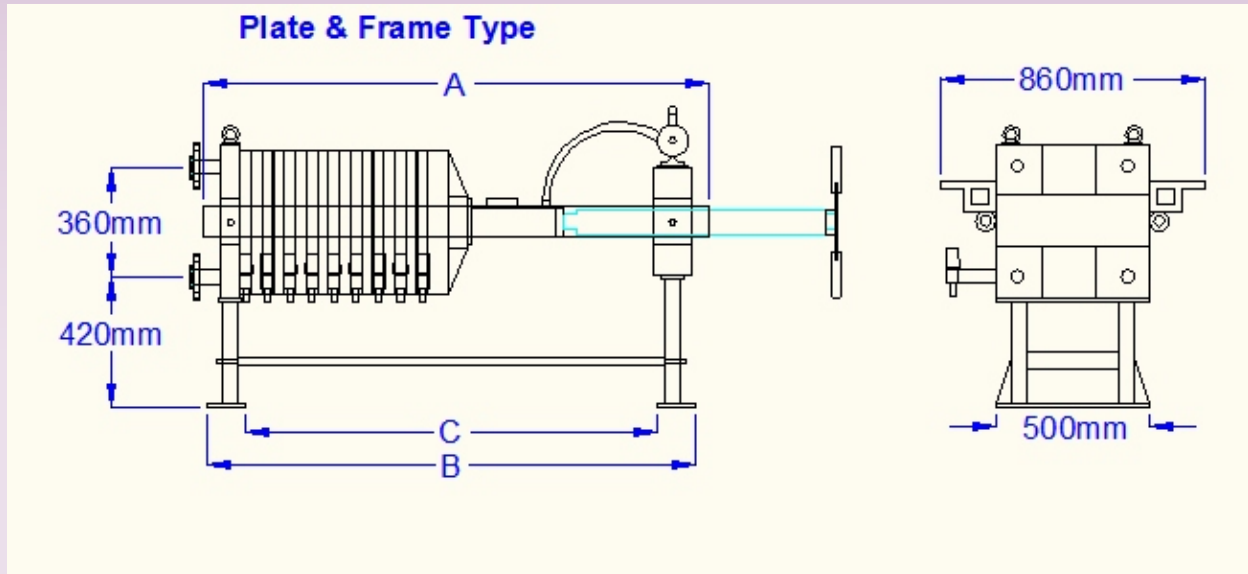

Size	No. of Frames	Thick in mm.	Cake Vol. In Liters	Area in Sq.m.	Dimension in mm		
					A	B	C
470 mm (18")	8	35	34.66	2.31	1650	1590	1340
	10	35	43.32	2.89	1800	1740	1490
	14	35	60.65	4.04	2100	2040	1790
	20	35	86.64	5.78	2550	2490	2240
	24	35	103.97	6.93	2850	2790	2540

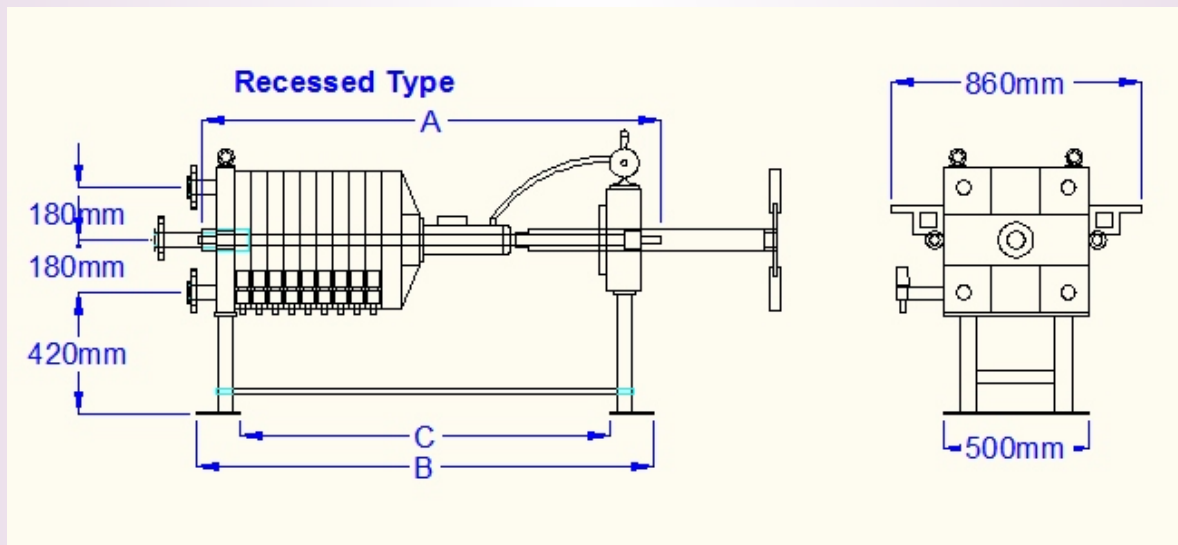

Size	No. of Frames	Thick in mm.	Cake Vol. In Liters	Area in Sq.m.	Dimension in mm		
					A	B	C
470 mm (18")	8	35	34.66	2.31	1600	1590	1290
	10	35	43.32	2.89	1700	1690	1390
	14	35	60.65	4.04	2000	1990	1690
	20	35	86.64	5.78	2400	2390	2190
	24	35	103.97	6.93	2650	2640	2340

All Dimensions are approximate confirm with us for exact details

\* For Manual closing A,B,C will be approximate 250mm less

\*\* For Motor Hydraulic closing A,B,C will be approximate 100mm less